

自動警報逆止閥

Model P(4")-C ALARM CHECK VALVE 100A(4")

CFC 自動警報逆止閥適用於消防系統上，它的本體為鑄鐵材質，兩端面為法蘭、青銅閥座及易於檢修的逆止蓋板及檢修口蓋若於檢查及保養時很容易的拆卸，不需將整套警報逆止閥拆下即可完成。經內政部消防署審核認可。

The CFC Alarm Check Valve is a general purpose rubber faced alarm check valve approved for fire service. The valve consists of a cast iron body with flange end connections, a bronze seat and a removable hand hole cover hinged to a rubber faced clapper assembly.

The cover and clapper assembly can be removed from the valve without removing the valve from the piping for easy inspection and maintenance. When pressure is exerted, the clapper moves from its seat and swings out of the path of flow. When the flow through the valve stops, the clapper quickly closes preventing reverse flow. approved by National Fire Administration Ministry of Interior R.O.C.

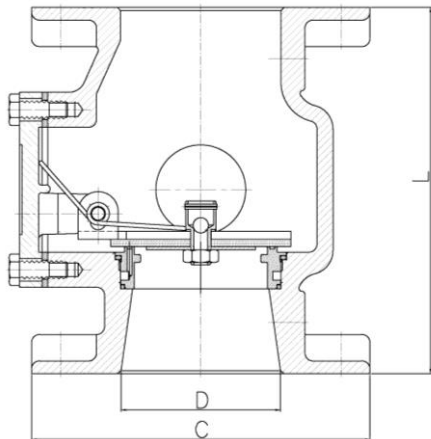
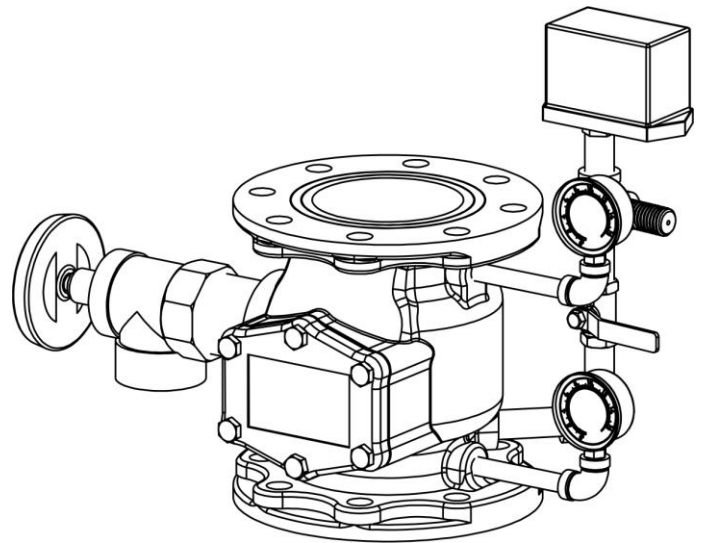

材質 MATERIALS

閥體/閥蓋 Body & Cover : FC 200 灰口鑄鐵
橡膠襯墊 Rubber : B II 714 Class NBR 橡膠
閥門 Clapper : SUS 304 不鏽鋼
閥座 Seat : BC6 青銅
彈簧 Spring : SUS 304 不鏽鋼

尺寸對照表

單位：mm

SIZE	L	C	D	螺栓孔數
100A	229	190.5	100	8

規範表

型式	P(4")-C
尺寸	100A(4")
安裝方向	垂直水平兩用
測試壓力	20kgf/cm ²
使用壓力範圍	1.5~14 kgf/cm ²
等價管長	5.69M
最大流量	2100 l/min
檢知流量係數	80
最低使用壓力 之不動作流量	10l/min